

MECHANICAL SEAL GLAND OPTIONS FOR WORTHINGTON D-1011, D-1021 PUMPS WHICH HAVE STUFFING BOXES.

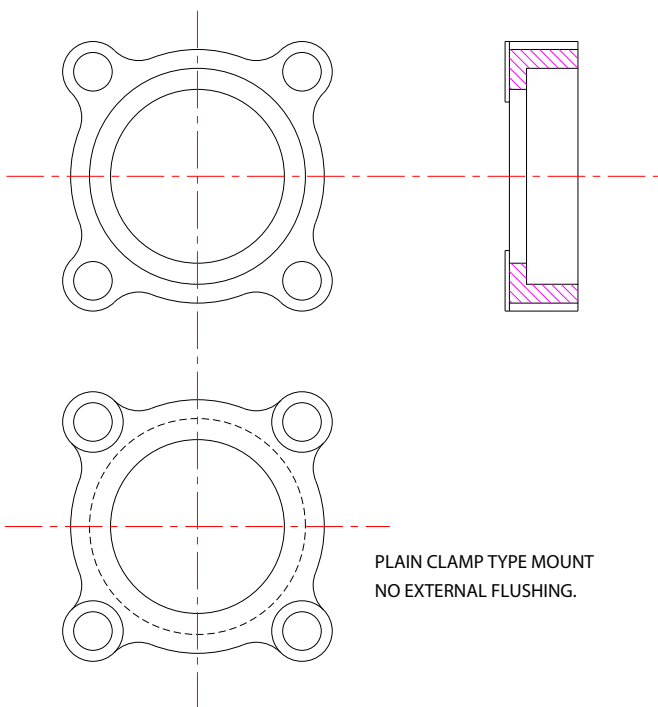

PLAIN CLAMP TYPE MOUNT
NO EXTERNAL FLUSHING.

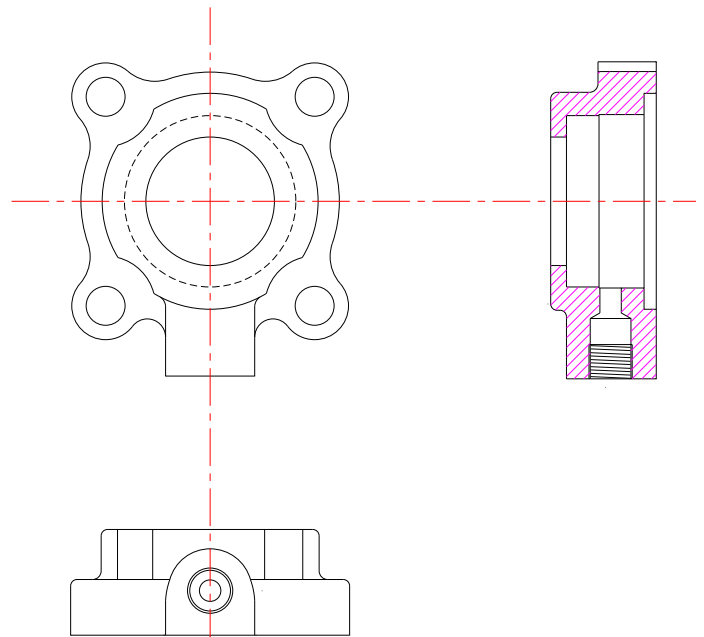

FLUSH GLAND, TAKES FLEX MOUNT TYPE
MECHANICAL SEAL SEAT WITH O-RING

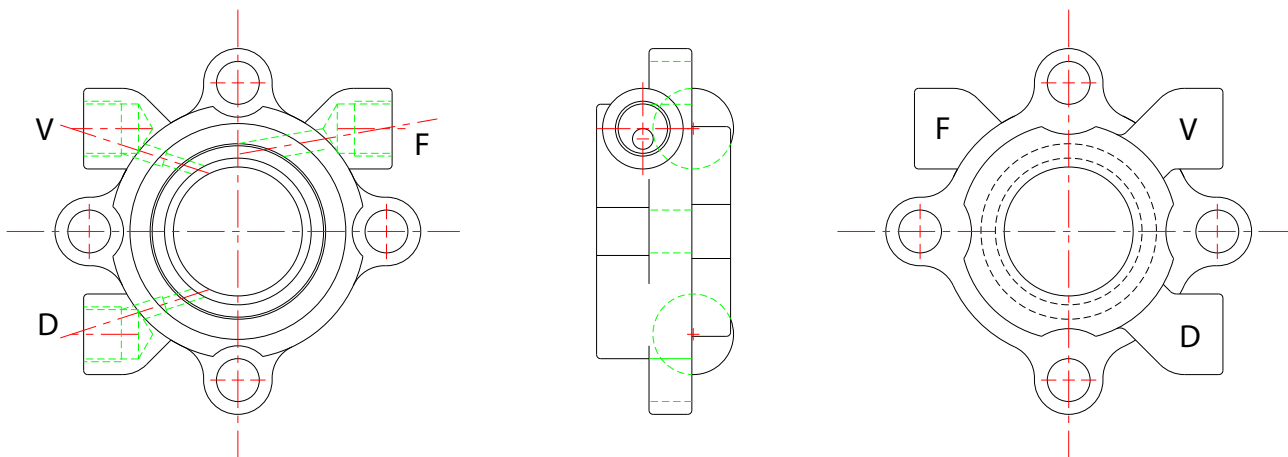

FLUSH-VENT-DRAIN GLAND, TAKES FLEX MOUNT
TYPE MECHANICAL SEAL SEAT WITH O-RING.

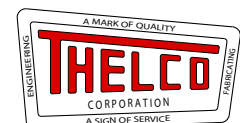
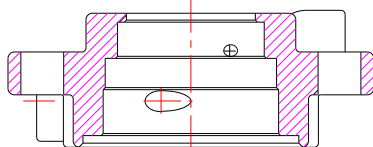

© Any reproduction must include
this copyright notice.

WORTHINGTON® is a registered trademark of Ingersoll-Dresser Pump Company.
Thelco is not affiliated with WORTHINGTON® or Ingersoll-Dresser Pump Company