

THELCO CUTAWAY DRAWING OF WORTHINGTON® PUMP MODEL D-1012 FRAME 1A, 2, 3, 4, AND 5.

Thelco Corporation Englewood, CO. USA  
www.thelco.com

PUMP SIZES: 2X1X10, 3X1-1/2X8, 3X1-1/2X10, 3X1-1/2X13, 3X2X6, 3X2X8, 3X2X10, 3X2X13,  
4X3X5, 4X3X6, 4X3X8, 4X3X10, 4X3X13, 6X4X6, 6X4X8, 6X4X10, 6X4X11, 6X4X13,  
8X6X11, 8X6X13, 8X6X15, 10X8X13, 10X8X15



© Any reproduction must include this copyright notice.

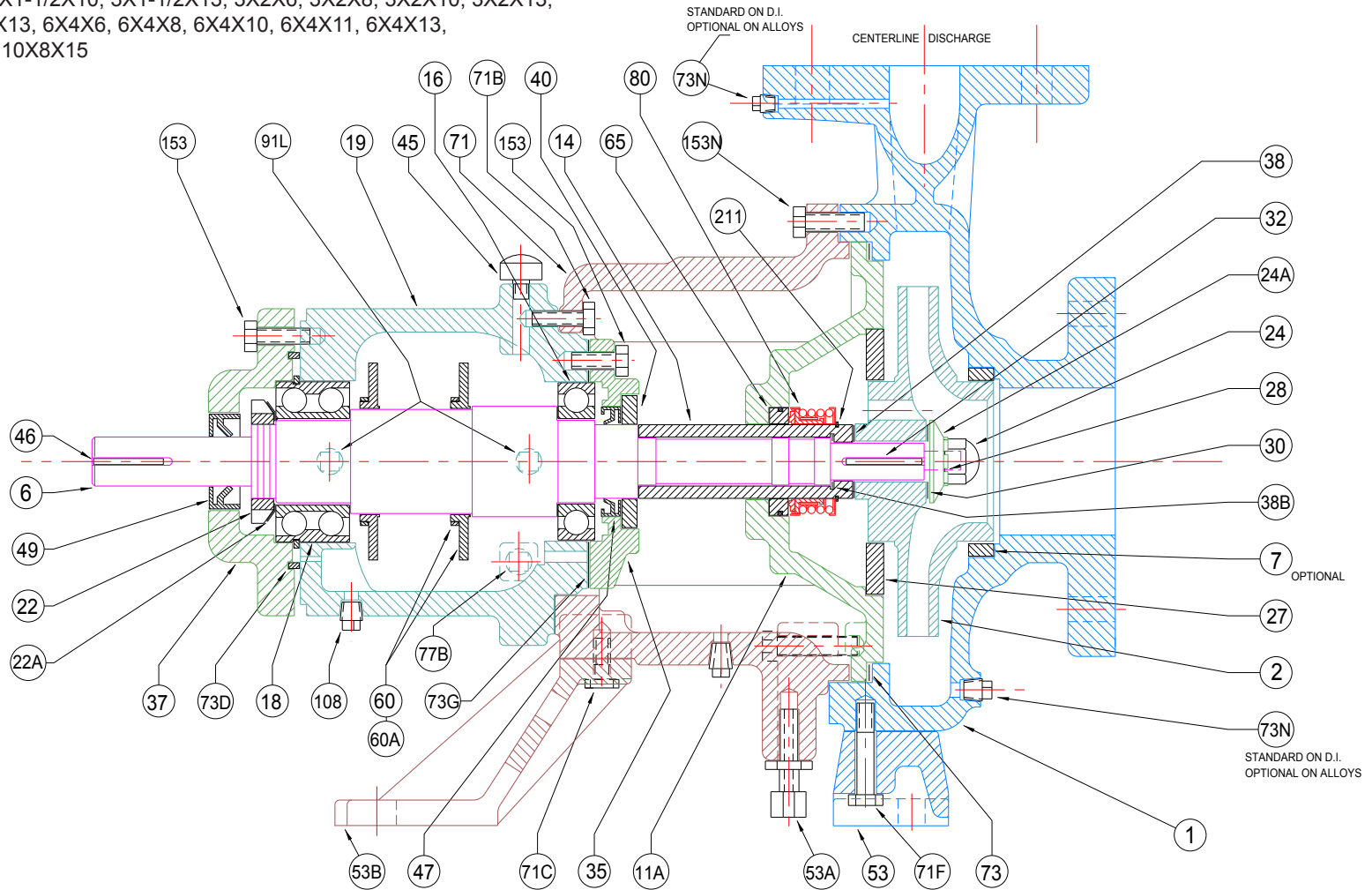
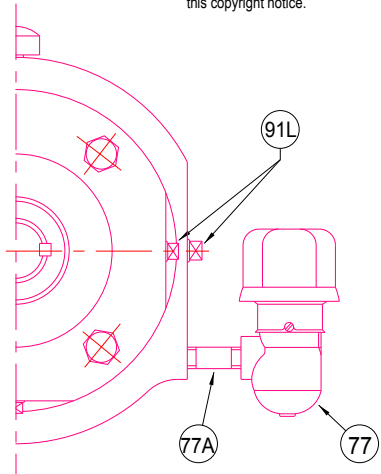

Note: Cut Shaft with Sleeve Version Shown.  
Solid Shaft Version is Dimensionally Similar to Cut Shaft Including Sleeve.  
Frm-1A Available in Cut Version Only.  
\*\*\* These Two Parts are not Included with the Solid Shaft Version.

\* Items contained in liquid end gasket kit.  
\*\* Items contained in frame end gasket kit

REFERENCE NUMBERS

WORTHINGTON® is a registered trademark of Ingersoll-Dresser Pump Company.  
Thelco is not affiliated with WORTHINGTON® or Ingersoll-Dresser Pump Company

1	CASING	27	RING, ADAPTER COVER	53	FOOT, CASING	73G	GASKET, LINE BEARING COVER **
2	IMPELLER	28	GASKET, IMPELLER NUT *	53A	ADAPTER SUPPORT, INBOARD	73N	PIPE PLUG, CASING
6	SHAFT (Shown Cut for a Sleeve)	30	GSKT, IMPELLER LOCK WASHER *	53B	ADAPTER SUPPORT	77	CONSTANT LEVEL OILER
7	RING, CASING (OPTIONAL)	32	KEY, IMPELLER	60	FLINGER, OIL	77A	NIPPLE, OILER
11A	MECHANICAL SEAL COVER	35	COVER, LINE BEARING	60A	COLLAR, OIL FLINGER	77B	PIPE PLUG, GREASE LUBE PUMPS
14	SLEEVE, SHAFT ***	37	COVER, THRUST BEARING	65	MECHANICAL SEAL SEAT	80	MECHANICAL SEAL ROTOR
16	LINE BEARING	38	GASKET, SLEEVE (OUTER) *	71	ADAPTER	91L	PIPE PLUG, OIL LUBE PUMPS
18	THRUST BEARING	38B	GASKET, SLEEVE (INNER) * ***	71B	CAP SCREW, ADAPTER	91L	GREASE FTG, GREASE LUBE PUMPS
19	BEARING HOUSING	40	DEFLECTOR	71C	CAP SCREW, ADAPTER FOOT	108	PIPE PLUG, DRAIN
22	LOCK NUT, BEARING	45	VENT CAP	71F	CAP SCREW, CASING FOOT	153	CAP SCREW, BEARING COVER
22A	WASHER, BRG LOCK NUT **	46	KEY, COUPLING	73	GASKET, CASING *	153N	CAP SCREW, CASING
24	NUT, IMPELLER	47	LIP SEAL, LINE BEARING **	73D	SEAL RING, THRUST BRG COVER **	211	RETAINING RING, SLEEVE
24A	LOCK WASHER, IMPELLER *	49	LIP SEAL, THRUST BEARING **				