

THELCO CUTAWAY DRAWING OF WORTHINGTON®
TWO STAGE SPLIT CASE PUMPS MODEL LLR.

Thelco Corporation Englewood, CO. USA
www.thelco.com

PUMP SIZES;
1-1/2LLR-7
1-1/2LLR-10
2LLR-9.

COUNTER CLOCKWISE
ROTATION CONFIGURATION
AS VIEWED FROM THE
COUPLING END.



© Any reproduction must include
this copyright notice.

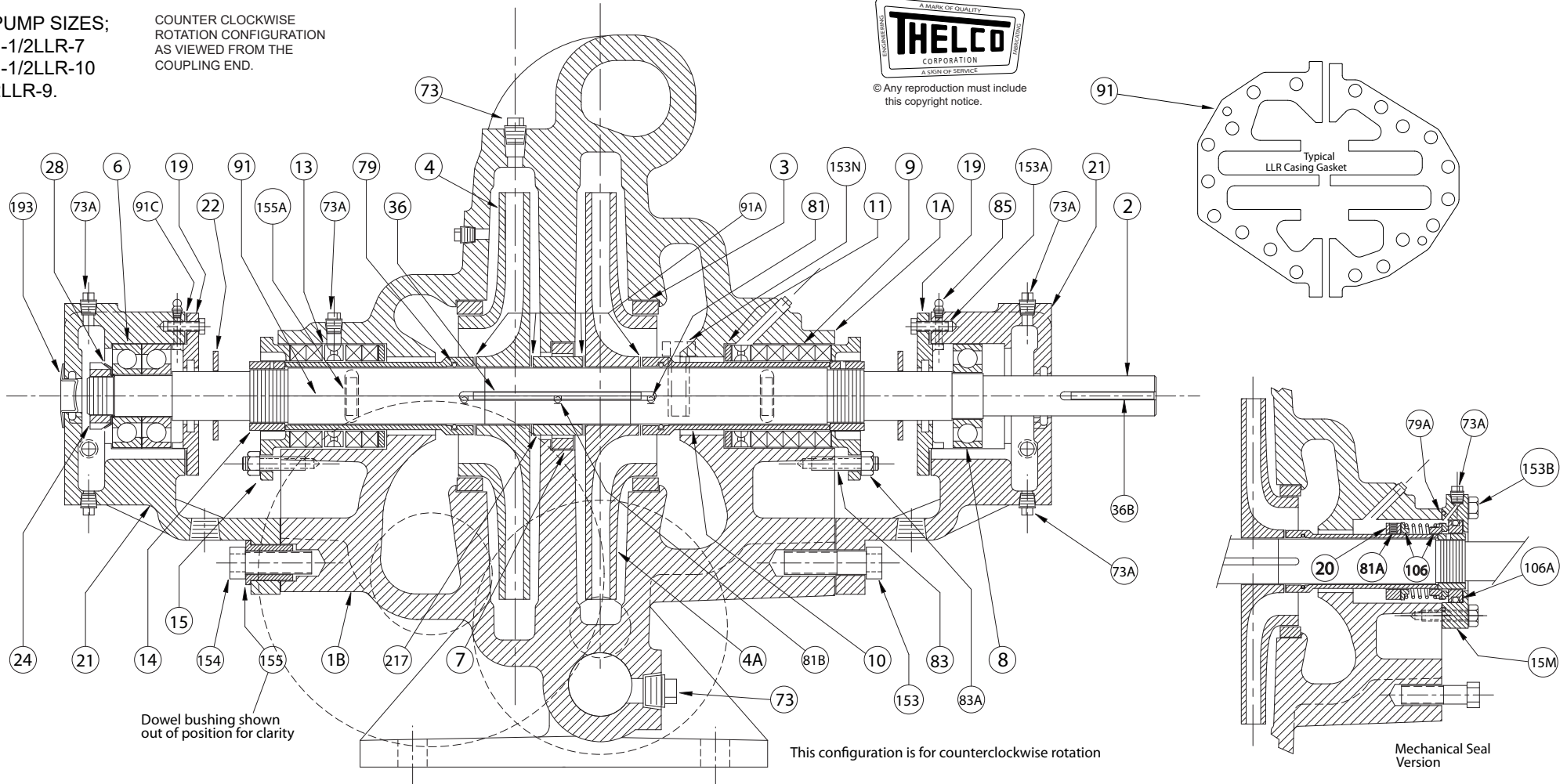

Dowel bushing shown
out of position for clarity

This configuration is for counterclockwise rotation

Mechanical Seal
Version

Optional Impeller/casing
Double Ring Repair Set Available.

WORTHINGTON® is a registered trademark of Ingersoll-Dresser Pump Company.
Thelco is not affiliated with WORTHINGTON® or Ingersoll-Dresser Pump Company

REFERENCE NUMBERS

1A	Casing, Upper Half	13	Seal Cage	73	1/2 inch Pipe Plug	91C	Gasket, Bearing Cover
1B	Casing, Lower Half	14	Shaft Nut	73A	1/4 inch Pipe Plug	106	Rotating Element, Mech Seal
2	Shaft	15	Gland, Packing	79	O-Ring, Shaft Sleeve	106A	Stationary Seat, Mech Seal
3	Casing Ring	15M	Gland, Mechanical Seal	79A	O-Ring, Gland M. S.	153	Cap Screws, Bearing Bracket
4	Impeller (first stage)	19	Bearing Cover	81	Set Screw, Casing Ring	153A	Cap Screws, Bearing Cover
4A	Impeller (second stage)	20	Mechanical Seal Collar	81A	Set Screw, Collar M.S.	153B	Cap Screw, Gland M.S.
6	Thrust Bearing Set	21	Thrust/Line Brg Bracket	81B	Set Screw, Intrstg Bush	153N	Cap Screws, Casing
7	Interstage Bushing	22	Deflector	83	Gland Stud	154	Dowel Bushing Screws
8	Line Bearing	24	Bearing Lock Nut	83A	Gland Nut	155	Dowel Bushings
9	Packing	28	Bearing Lock Nut Washer	85	Grease Fitting 1/8 NPT	155A	Roll Pin
10	Shaft Sleeve	36	Key, Impeller	91	Gasket, Casing	193	Dust Cover
11	Stuffing Box Bushing *	36B	Key, Coupling	91A	Gaskets, Spacer / Sleeve	217	Spacer Sleeve

* Packed Box Only

March 2019

Page 41