

THELCO CUTAWAY DRAWING OF WORTHINGTON®
SPLIT CASE PUMP MODEL LR .

Thelco Corporation Englewood, CO. USA

www.thelco.com

PUMP SIZES;

10LR-17
10LR-18

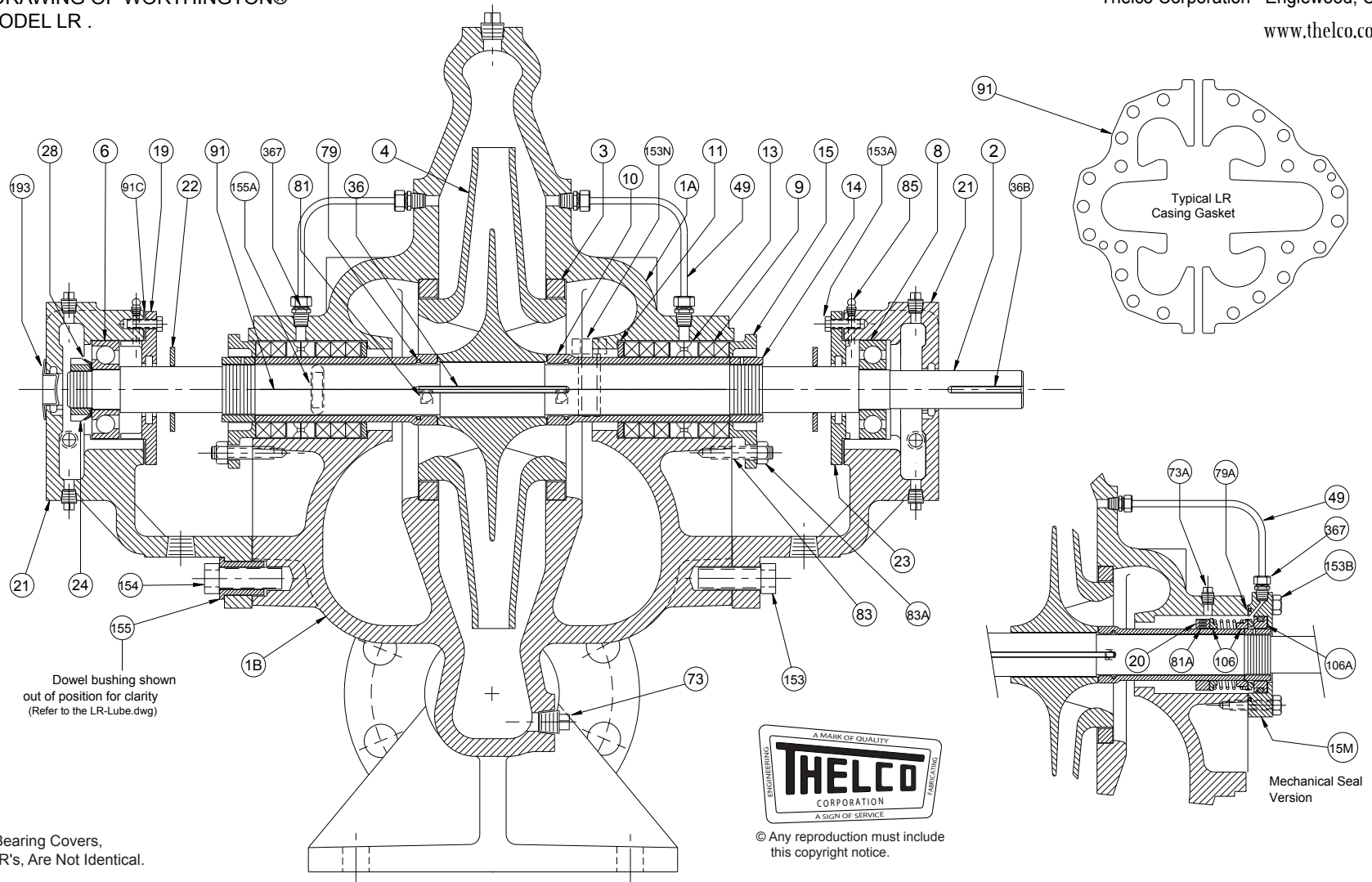

Note: Line and Thrust Bearing Covers,
Unlike in Other LR's, Are Not Identical.

An Optional Impeller/Casing
Double Ring Repair Set Available.

WORTHINGTON® is a registered trademark of Ingersoll-Dresser Pump Company.
Thelco is not affiliated with WORTHINGTON® or Ingersoll-Dresser Pump Company

REFERENCE NUMBERS

1A	Casing Upper Half	15	Gland, Packing	49	Flush Tube, Optional	106	Rotating Element Mech Seal
1B	Casing Lower Half	15M	Gland, Mech Seal	73	1/2 inch Pipe Plug	106A	Stationary Seat Mech Seal
2	Shaft	19	Bearing Cover, Thrust	73A	1/4 inch Pipe Plug	153	Bearing Bracket Screws
3	Casing Ring	20	Mechanical Seal Collar	79	O-Ring, Shaft Sleeve	153A	Bearing Cover Cap Screws
4	Impeller	21	Thrust/Line Brg Bracket	79A	O-Ring, Gland M. S.	153B	Cap Screw, M. S. Gland
6	Thrust Bearing	22	Deflector	81	Set Screw, Casing Ring	153N	Casing Split Cap Screws
8	Line Bearing	23	Bearing Cover, Line	81A	Set Screw, Collar M.S.	154	Dowel Bushing Screws
9	Packing	24	Bearing Lock Nut	83	Gland Stud	155	Dowel Bushings
10	Shaft Sleeve	25	Bearing Spacer	83A	Gland Nut	155A	Roll Pin
11	Stuffing Box Bushing *	28	Bearing Lock Nut Washer	85	Grease Fitting, 1/8 NPT	193	Dust Cover
13	Seal Cage	36	Impeller Key	91	Casing Gasket	367	Compression Fitting
14	Shaft Nut	36B	Coupling Key	91C	Bearing Cover Gasket		

* Packed Box Only